

Economic Development Incentive Program

Briefing

Update on Pratt & Whitney Announcement

November 5, 2020



Pratt and Whitney

Background:

- **Announced October 22nd**, Pratt & Whitney (PW) has chosen Buncombe County for its expansion.
- Designer and manufacturer of **aircraft engines and auxiliary power** systems for commercial, military, and business aircraft.
- **Fortune 39 Employer with approximately 40K employees** and \$21B in revenue in 2019.
- **Subsidiary of Raytheon Technologies** after the April 2020 merger with United Technologies.
- Further bolsters Buncombe County as an **aerospace hub in the Southeast.**



Scope of Project

Pratt and Whitney will:

- **Construct 1M sqft facility in Biltmore Park West**
- **Create 800 new jobs;**
- **Invest \$650.0 million in real and business personal property;**
- **Provide an average wage of \$68K annually (\$32.69 hourly); and**
- **Create a direct impact of \$54M in local labor income and one-time construction impacts totaling 600+ direct jobs.**

Aligns to Strategic Plan Goals for increasing average wages and total employment.



Site Layout and Location



Geared Turbofan (GTF) Engine

GTF ENGINE FAMILY

FOR LARGE COMMERCIAL AIRCRAFT
AND REGIONAL JETS

17,000 – 33,000
Pounds Thrust Class

16%

Improvement in
fuel efficiency

50%

Reduction in
regulated NOx
emissions

75%

Reduction in
noise footprint

Pratt & Whitney geared turbofan

A geared turbofan engine has a gearbox between the front fan and the shaft to the engine core, so that the speed of the front fan can be decoupled from the speed of the core. This way, the engine can safely drive a larger fan and push a larger volume of air, while the low-pressure compressor and turbine blades spin faster, boosting fuel efficiency.

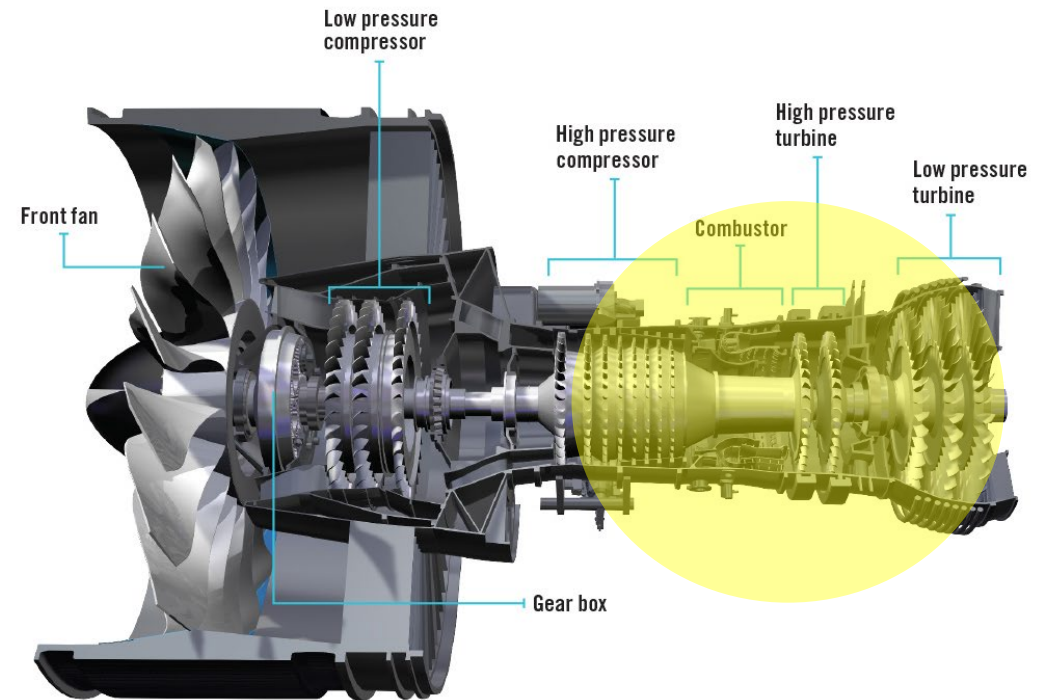

Current Terms

- **Performance Commitments:**



- **Jobs:** Create **800 new jobs**;
- **Direct Investment:** Invest **\$650.0 million** in real and business personal property; and
- **Average Wage:** Provide an **average wage of \$68K annually** (\$32.69 hourly).

- **Incentive:**

- **Total:** \$27M
- **Annual:** \$2.6M (estimated)
- **Term:** not less than 10 years
- **Payout Structure:** pay-for-performance based on actual job, investment, and average wages created



Project Impacts

	<ul style="list-style-type: none">• SUPPORTS 1,264 TOTAL DIRECT, INDIRECT, INDUCED JOBS• \$74M IN NEW PAYROLL• ANNUAL TAX IMPACTS: \$2.5M LOCAL \$6.1M NC \$23M US
	<ul style="list-style-type: none">• \$650M TOTAL INVESTMENT
	<ul style="list-style-type: none">• CONSTRUCTION SUPPORTS 1,029 TOTAL DIRECT, INDIRECT, INDUCED JOBS• \$53M IN NEW PAYROLL• 1-TIME TAX IMPACTS: \$1.3M LOCAL \$2.8M NC \$9.7M US



Project Impacts

	<ul style="list-style-type: none">• \$5M A-B TECH TRAINING FACILITY• 10 YEAR \$2.6M CUSTOM TRAINING COMMITMENT
	<ul style="list-style-type: none">• TBD MANUFACTURING EMPLOYMENT GROWTH, REGIONAL GRP GROWTH, SUPPLIER AND RELATED INDUSTRY LOCATIONS
	<ul style="list-style-type: none">• TBD IMPACTS IN CORPORATE PHILANTHROPY, HIRING PRACTICES & BENEFITS, HOME OWNERSHIP, ECONOMIC MOBILITY, GLOBAL COMPETITIVENESS

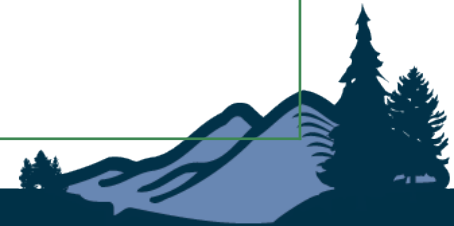

Partnership

- **Joint economic development effort between:**
 - **North Carolina Department of Commerce:** economic development incentives
 - **A-B Tech:** customized training and training center
 - **Golden Leaf Foundation:** bridge infrastructure
 - **Biltmore Farms:** land grant
 - **Economic Development Coalition (EDC):** project management
 - **Community Betterment Foundation (CBF):** grant administration
 - **Buncombe County:** economic development incentives



Next Steps

- **Notice of Public Hearing:** published November 4th 2020
- **Public Hearing:** November 17th 2020
 - Formal vote on economic development agreement and incentives



Appendix

